

# TEM<sub>00</sub> HIGH PULSE ENERGY Nd:YAG LASER

## LQ830

SOLAR LS presents a new innovative Nd:YAG laser with a unique combination of technical specifications.



The LQ830 provides high-power and high-quality TEM<sub>00</sub> radiation in a compact and cost-effective design. The unique combination of output parameters makes this laser a perfect tool for fulfilling the most demanding and ambitious scientific applications.

The master oscillator with extremely stable ring cavity, preamplifier and high-power amplifying stage form the output single-mode radiation with low divergence, high pulse energy and Gaussian far field beam profile. Thanks to the intra-cavity Fabry-Pérot interferometer option the radiation linewidth can be reduced down to 0.1 cm<sup>-1</sup>.

The LQ830 while possessing exceptional characteristics is easy in operation and reliable – you do not need to be a laser expert to use it. You can just

concentrate on your experiments and applications without thinking that you operate a high-tech device.

The LQ830 offers maximum flexibility for automation of experiments or when you wish to integrate it into automated technological process. The laser can be remotely operated via a full RS232 port for high precision time-critical applications.

Dust filtration system allows not only to operate but also to service the laser in rooms with no special cleanliness requirements which considerably simplifies service and reduces its cost.

## FEATURES

- TEM<sub>00</sub>, M<sup>2</sup> ≤ 2
- Output energy up to 0.7 J
- Spectral linewidth of 0.1 cm<sup>-1</sup>
- Divergence < 0.5 mrad
- Perfect stability
- Built-in VIS and UV harmonic generators
- Rugged and small footprint design

## APPLICATIONS

- Optical holography and interferometry
- Raman and resonance spectroscopy
- Nonlinear optics and plasma physics
- Material processing
- OPO and DFB lasers pumping
- UV photolithography
- LIDAR / DIAL

## SPECIFICATIONS \*

Model	LQ830	
	with FPI <sup>1)</sup>	Without FPI
Max pulse repetition rate <sup>2)</sup> , Hz	20	
Pulsed energy, mJ		
at 1064 nm	600	700
at 532 nm	400	450
at 355 nm	250	300
at 266 nm	120	130
at 213 nm <sup>3)</sup>	50	50
Linewidth <sup>4)</sup> , cm <sup>-1</sup>	0.1	1
Pulsewidth (FWHM) <sup>4)</sup> , ns	6...9	
Beam diameter <sup>4)</sup> , mm	< 7.5	
Beam quality <sup>4)</sup>	TEM <sub>00</sub> , M <sup>2</sup> < 2	
Divergence <sup>4)</sup> , mrad	≤ 0.5	
Beam pointing stability <sup>4)</sup> , μrad		
in horizontal plane	± 6	
in vertical plane	± 20	
Pulse energy stability (StdDev) <sup>4)</sup> , %	< 1	
Jitter (StdDev) <sup>5)</sup> , ns	< 1	
Electrical service	200...240V, 50/60 Hz, <1000W	
Dimensions, mm:		
Laser Head (LxWxH)	590 x 322 x 130	
Power Supply (HxWxD)	695 x 367 x 700	

\* Specifications are subject to change without notice.

1) With intra-cavity Fabry-Pérot interferometer.

2) You can choose any PRR from 1Hz to 20Hz when placing an order. All the parameters are specified for 10 Hz.

3) With external LG105 unit.

4) Specified at 1064 nm.

5) With respect to QSW IN pulse.

## OPTIONS

- External attenuators

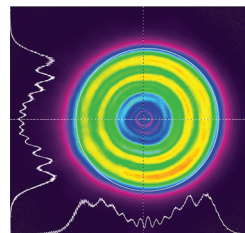

LQ830 laser typical near field beam profile.

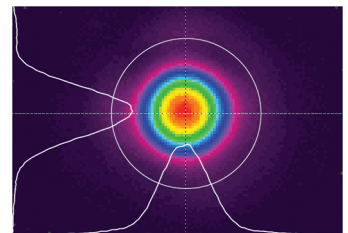

LQ830 laser typical far field beam profile.

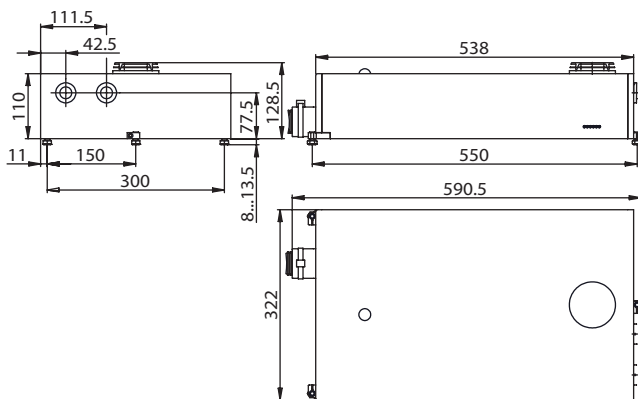

LQ830 laser head outline drawing.

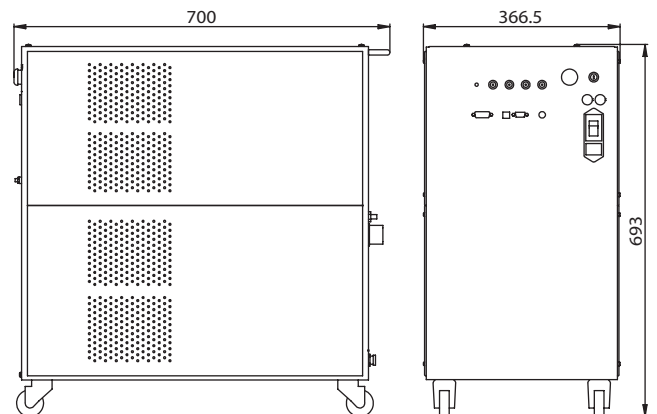

LQ830 laser power supply outline drawing.